



IEG

Leibniz-Institut für  
Europäische Geschichte

Mitglied der  
*Leibniz*  
Leibniz-Gemeinschaft

# RelRes DHC Digital Humanities Course Mainz

## RETOPEA: Digital data management and curation

Marco Büchler, Ilenia Laudito





# Table of Content

1. RETOPEA Project
2. Workflow
  1. Readability
  2. Metadata
  3. Automatic Translations
3. Data Management in Omeka



# RETOPEA

(RELigious TOLeration and PEAcE)

The basic concept is that **insight into historical religious peace-making** offers a prism for **interpreting contemporary problems related to religious diversity**.

Emphasis on active and reflective learning from history for

academic research

development of **docutubes**

An important feature is that the project challenges **teenagers** with different cultural, national and ethnic backgrounds **to interpret the results of new historical research themselves** – in contrast to existing approaches in which young people are only passive receptors.



## Partners & WPs

RETOPEA consists of an interdisciplinary consortium of academic and non-academic partners including:

Germany	IEG
Belgium	KU Leuven, Le Foyer
Spain	Uni Granada
UK	Open University
Estonia	Uni Tartu
Macedonia	UKIM, MCIC
Finland	Uni Helsinki
Poland	Warsaw

WP1	Scientific Coordination
WP2	Historical research
WP3	Contemporary research
WP4	Data management & curation
WP5	Educational impact
WP6	Policy impact
WP7	Dissemination and communication

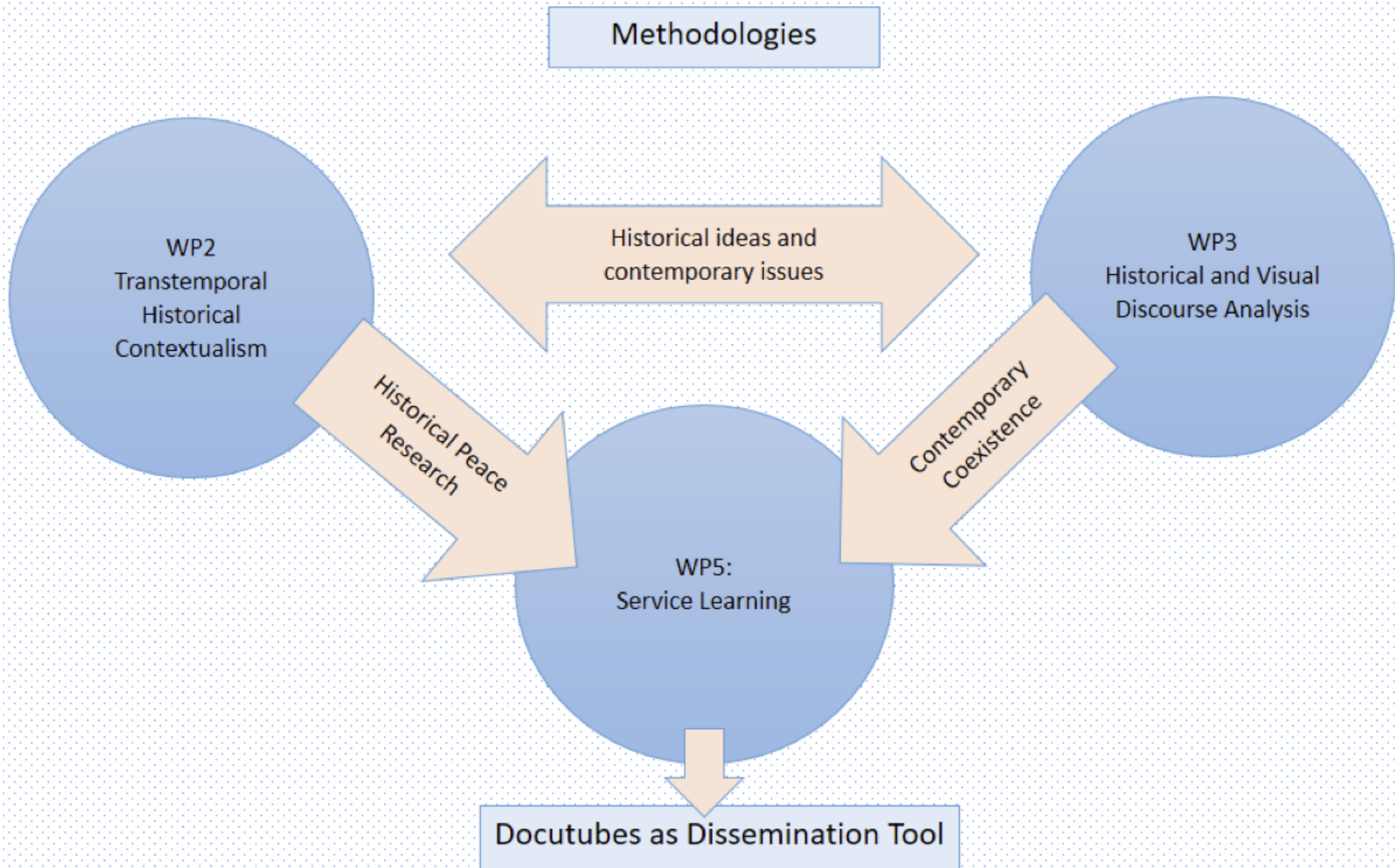



# Why a workflow?

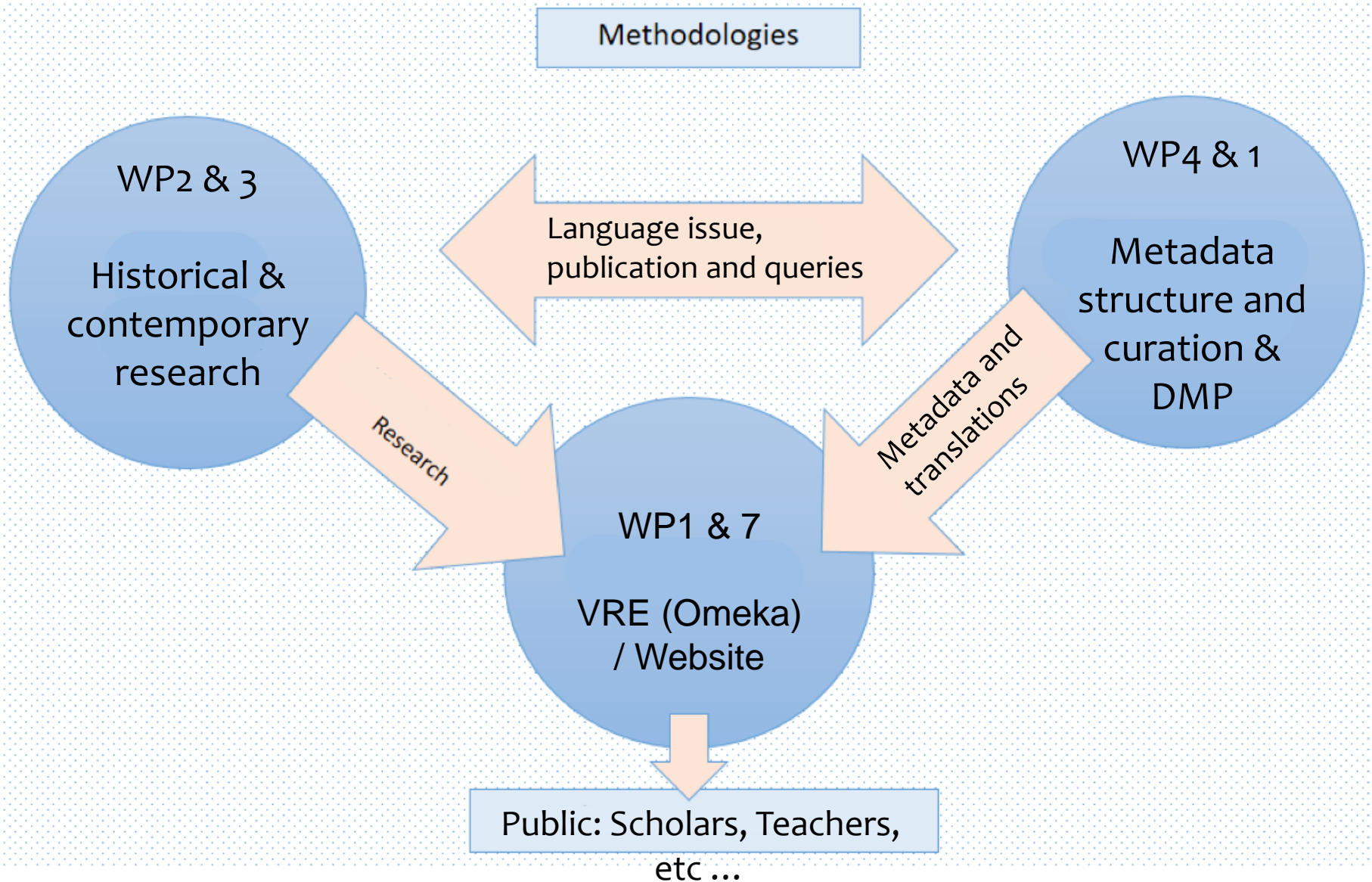



# Glossary

<b>Clipping</b>	A summary/abstract of a certain subject, in any format (video, audio, text, etc...).
<b>Source clipping</b>	Original clipping version (English written).
<b>Clipping bundle</b>	Composed of the source clipping and all its translations.
<b>Clipping Holder</b>	First author. Person responsible for the whole clipping.
<b>Language Reviewer</b>	Person responsible for the correctness of the translated clipping in the respective language.



## Workflow of multi-lingual data ingestion

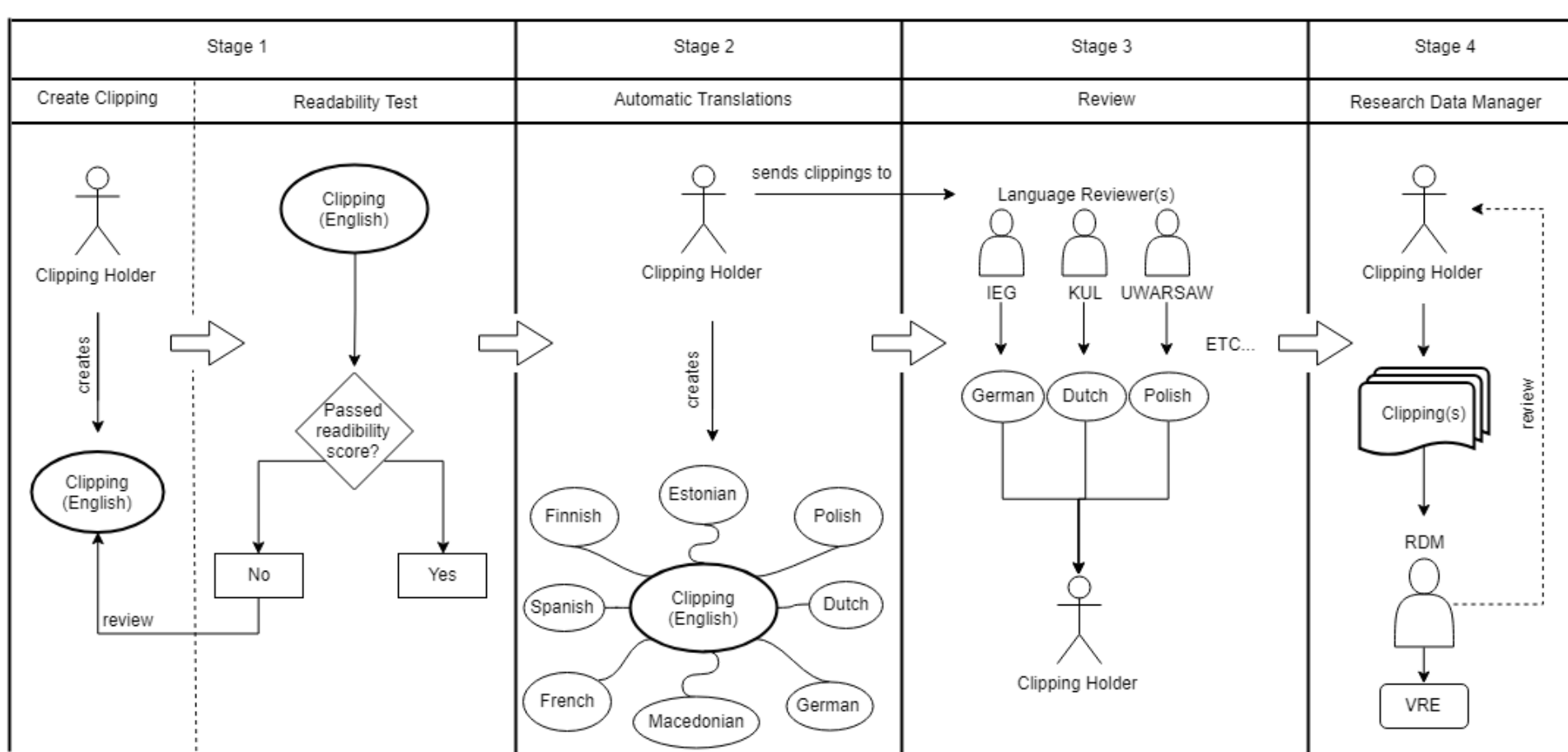





## Stage 1: Creating the Clipping

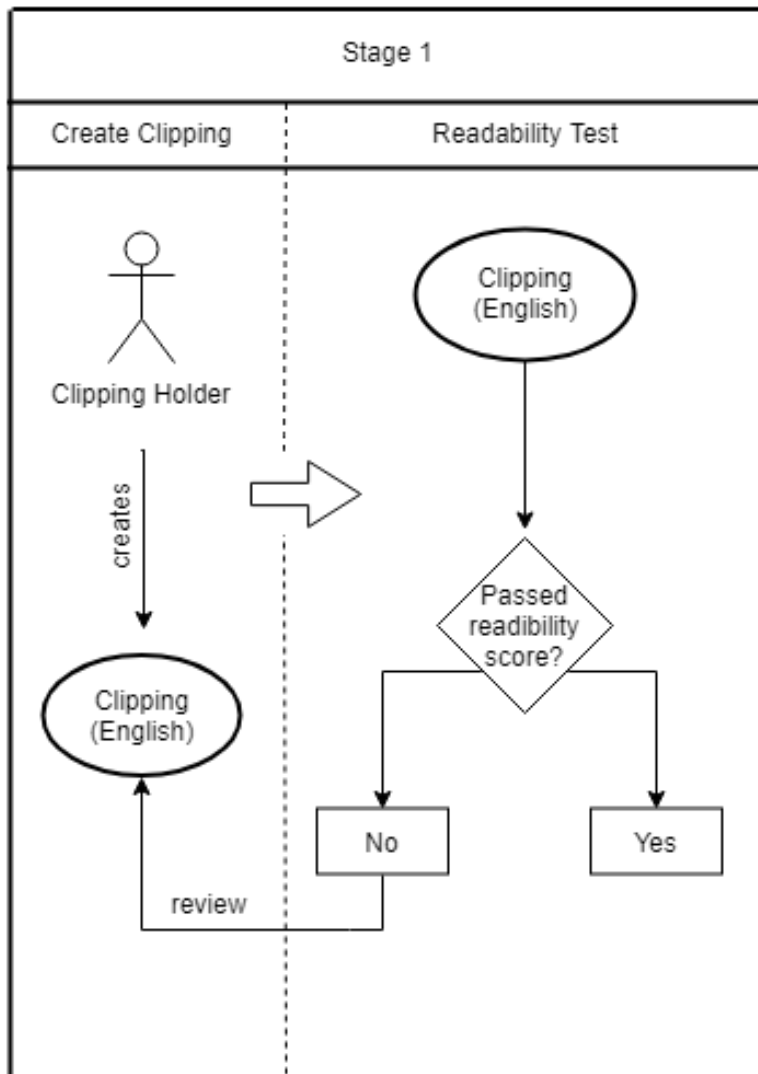

- All **source** clippings must be written in **English**:

English reviews are highly recommended

- For longer and complex written texts a **readability test** is necessary to match pupil's reading level
- Procedure for video and/or audio files will be defined later on.



## Stage 1.1: Readability test

Ensures the appropriate understanding level for its target.

Target group's **age**: between 13 and 18 years

Target group's **grade**: between 9<sup>th</sup> and 13<sup>th</sup> (ref. to UK school system)

The relevant scores for each test in prioritized order are as follows:

	Flesch-Kincaid reading ease score	ARI (automated readability index)	SMOG index	Flesch-Kincaid grade level	Gunning Fog index	Coleman-Liau index
Score	90.0 - 50.0	7 - 12	6-12	6-12	6-12	6-12

For detailed information please visit this [link](#)



## Example

### Example 1:

»The Peace of Augsburg was a treaty signed between Charles V, Holy Roman Emperor, and the forces of the Schmalkaldic League on September 25, 1555 at the city of Augsburg in Germany.«

### Example 2:

»The Peace of Augsburg was a treaty signed between Charles V, Holy Roman Emperor, and the forces of the Schmalkaldic League. **The treaty was signed** on September 25, 1555 at the city of Augsburg in Germany.«

	Flesch-Kincaid reading ease score	ARI (automated readability index)	SMOG index	Flesch-Kincaid grade level	Gunning Fog index	Coleman-Liau index
Score	90.0 - 50.0	7 - 12	6-12	6-12	6-12	6-12
Example 1	44.8	15	11.6	15	12.8	9.8
Example 2	61.7	8.1	8.3	9	7.2	9.9



## Stage 1.2: Metadata

- All the clippings will have a **structured metadata** vocabulary ([Dublin Core Standard](#))
- Translation and management of semantic variations of metadata with [Babelnet](#) (i.e. image captions, metadata keywords, etc...) <http://live.babelnet.org>



BabelNet

antwerp ENGLISH 7 AUSGEWÄHLT ÜBERSETZEN

PRÄFERENZEN

Alle



9 Ergebnisse

• Nomen

### Nomen



#### Antwerp, Antwerpen, Anvers

A busy port and financial center in northern Belgium on the Scheldt river; it has long been a center for the diamond industry and the first stock exchange was opened there in 1460

ID: 00004791n | Named Entity

NL antwerpen

ET antwerpen

FI antwerpen

FR anvers

DE antwerpen, Antorf, Antorff

MK антврпен

ES amberes, antwerpen, anvers



## Stage 2: Automatic translations

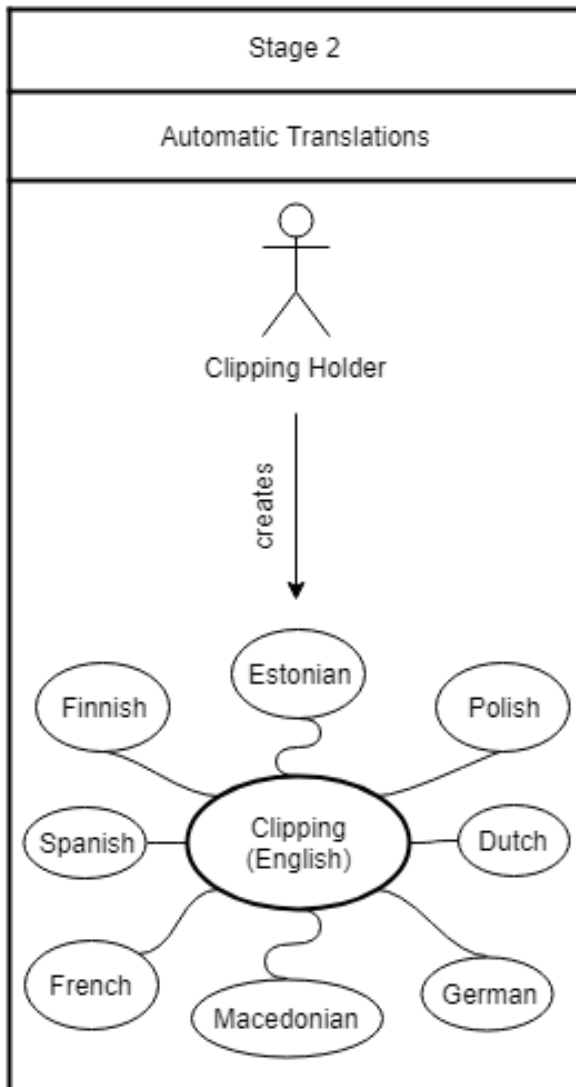

DeepL is recommended for translations from English to **German, French, Spanish, Polish and Dutch**

<https://www.deepl.com/translator>

## Stage 2: Automatic translations

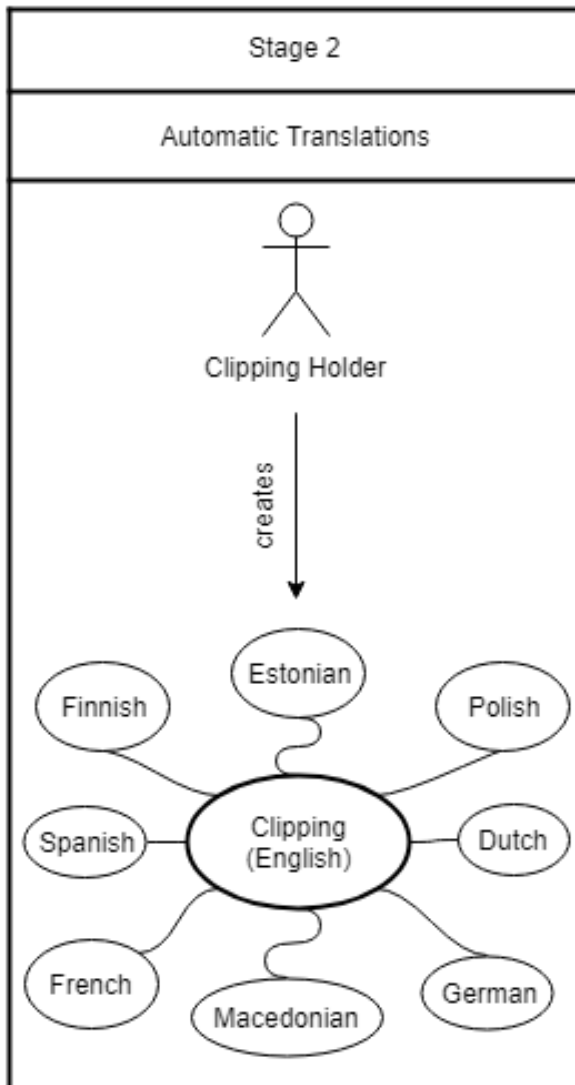

For translations from English to **Macedonian, Finnish and Estonian** these tools are recommended:

- Macedonian:  
<http://masintolge.ut.ee/en>
- Finnish:  
<http://matrix.statmt.org>
- Estonian:  
<http://www.tilde.ee/masintolge>

## Stage 3: Translation reviews

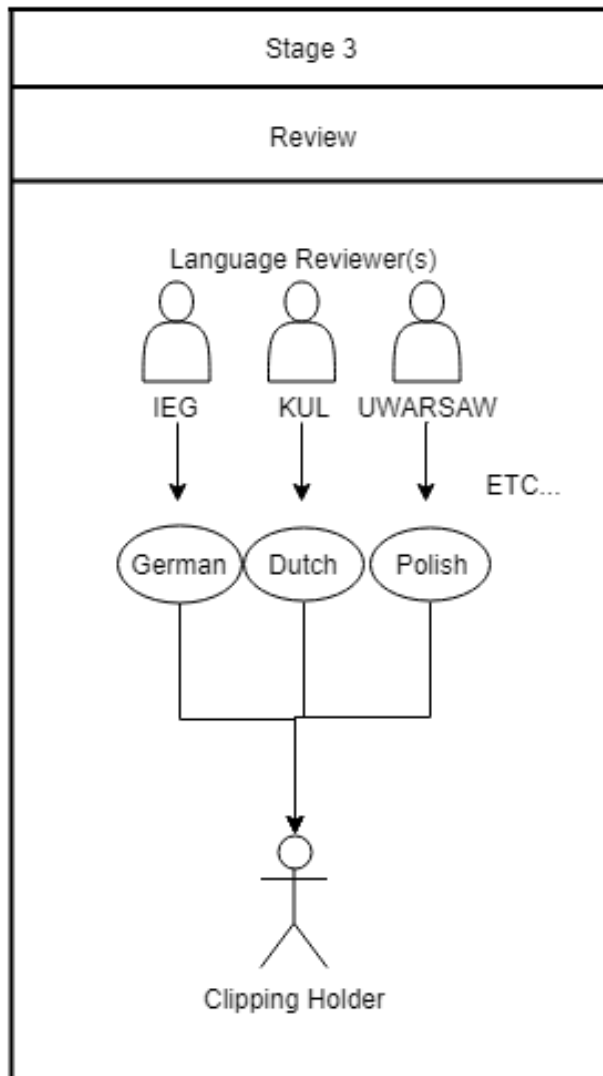

The **Clipping Holder** is responsible for the quality and correctness of the **source clipping**.

Each institution nominated a **Language Reviewer**, who will be responsible for the quality and correctness of the **translated clipping**.

## Stage 3: Translation reviews

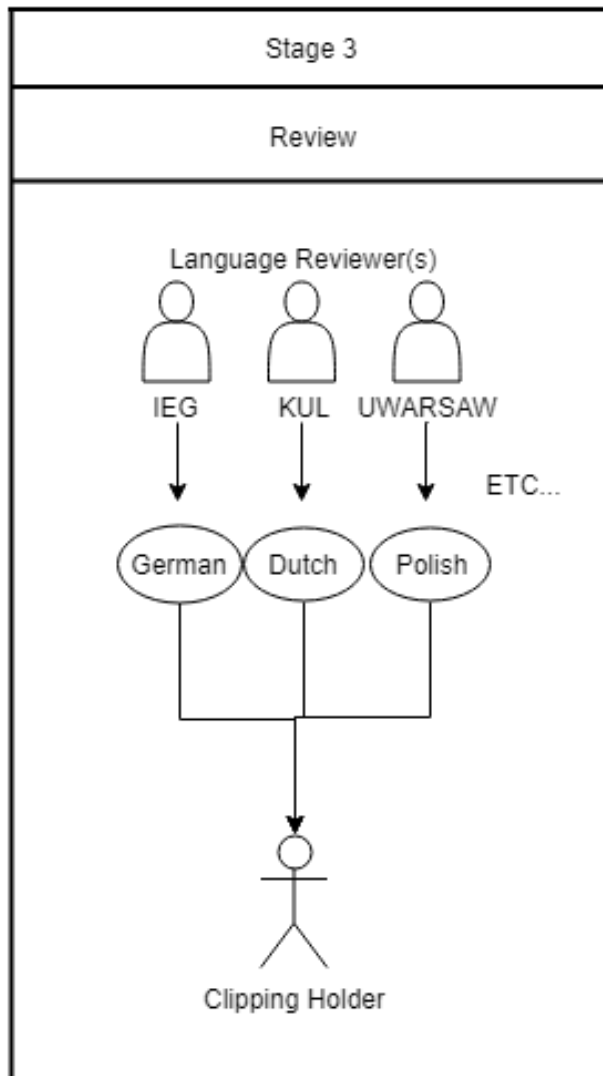

The **Clipping Holder** sends the automatically translated clipping to the **Language Reviewers**.

The Language Reviewers will send the examined and reviewed version of the clipping back to the Clipping Holder.



## Stage 4: Final review

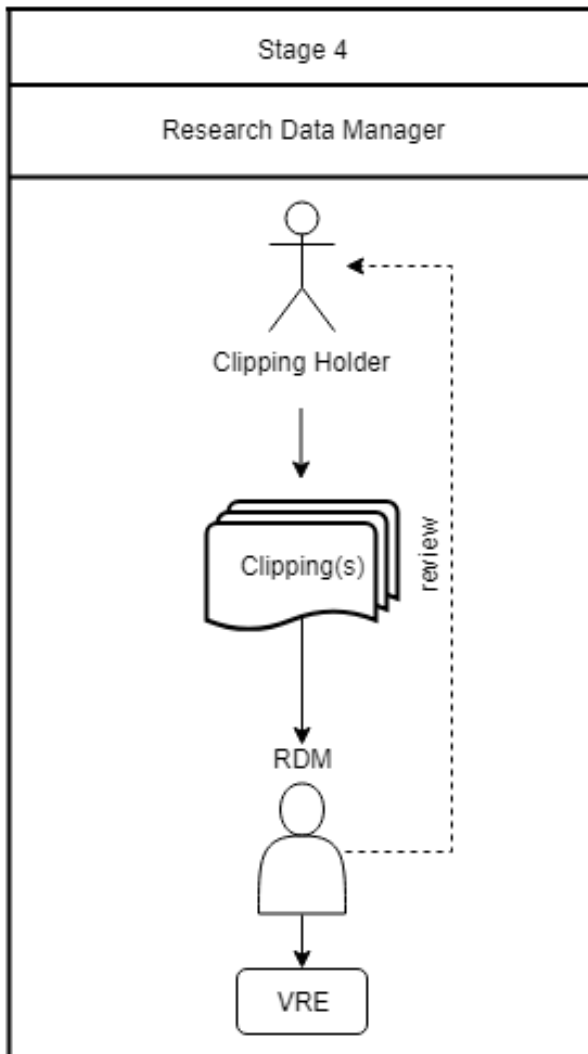

The Clipping Holder sends the **clipping bundle** to the **RDM**, who will re-examine the clipping bundle, before inserting and integrating it in the VRE.

If the clipping bundle presents imprecisions, the RDM will send the clipping bundle back to the Clipping Holder for reexamination.



IEG

Leibniz-Institut für  
Europäische Geschichte

Mitglied der

Leibniz  
Leibniz-Gemeinschaft

QUESTIONS?





IEG

Leibniz-Institut für  
Europäische Geschichte

# Omeka

- Omeka S is a web publication system for universities, galleries, libraries, archives, and museums.
- Omeka provides open-source web publishing **platforms for sharing digital collections** and creating media-rich online exhibits

[www.retopea.eu](http://www.retopea.eu)



IEG

Leibniz-Institut für  
Europäische Geschichte

# Hands-on

Go to →

1. <http://retopea.eu/s/test-site/page/welcome>
2. [Google Drive](#)